

**CARATTERISTICHE ELETTRICHE**  
**ELECTRICAL FEATURES**
**Voltaggio**

Voltage 220 Volt

**Tension**

Tension 50 Hz

**Potenza motore**
**IDROMASSAGGIO** 0,8 hp (Standard)  
 WHIRPOOL motor power 1,00 hp (4 mini-jet)

**Potenza assorbita**
**IDROMASSAGGIO** 810 Watt (Standard)  
 WHIRPOOL absorbed power 930 Watt (4 mini-jet)

**Potenza motore**
**AIRPOL**  
 AIRPOL motor power 0,9 hp

**Potenza assorbita**
**AIRPOOL**  
 AIRPOOL absorbed power 700 Watt

**Stabilizzazione temperatura**

Temperature stabilize 1300 Watt

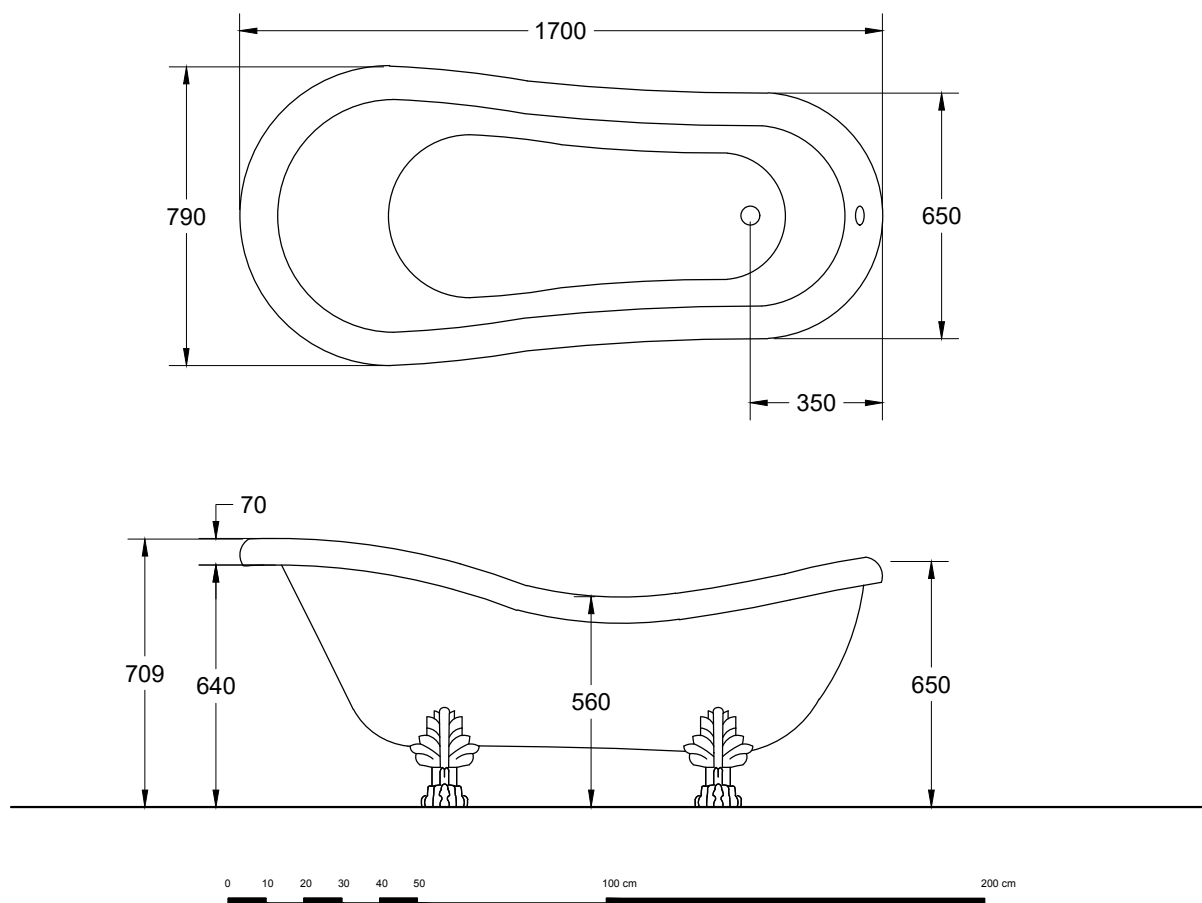
**Cassiopea**

Contenuto Acqua <sup>(1)</sup> Water Content <sup>(1)</sup> lt	Peso di spedizione Delivery Weight kg	Volume di spedizione Delivery Volume m <sup>3</sup>
165	60	1,29

## Installazione idraulica / Hydraulic Installation

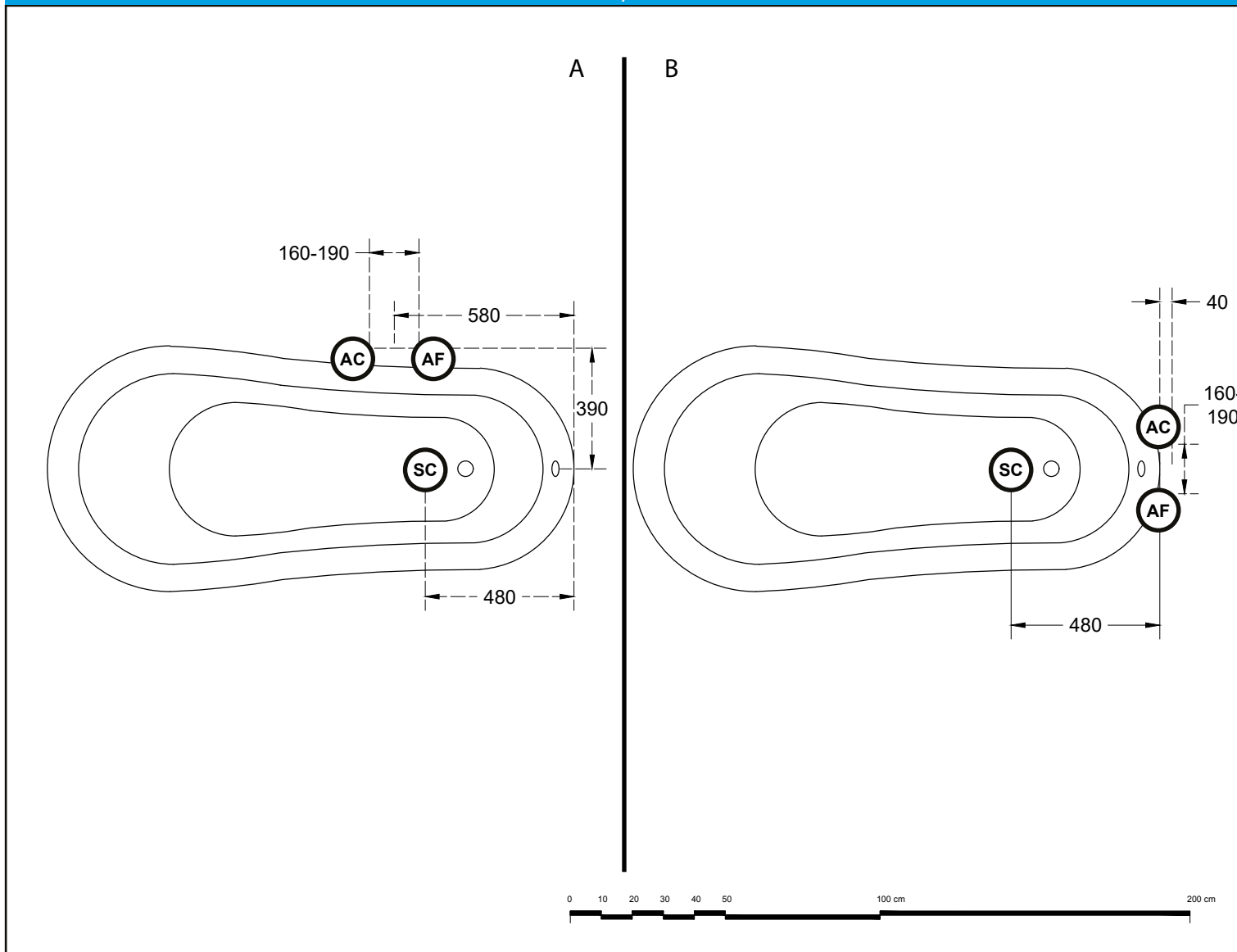

**A monte dell'impianto idraulico si consiglia di installare dei rubinetti filtro.  
L'Azienda declina problemi derivanti dalla mancata installazione dei suddetti**

Allaccio acqua calda nel caso di vasca provvista di rubinetteria

Allaccio acqua fredda nel caso di vasca provvista di rubinetteria

Scarico a terra consigliato



*Hot water connection should the bathtub be fitted with taps*

*Cold water connection should the bathtub be fitted with taps*

*Recommended grounded drain*